



automation software technology

## Stay ahead of the curve with the most flexible and powerful automation software on the market.

ISaGRAF is a comprehensive set of software technologies used to develop leading-edge local or distributed control products. The technology is designed to be scalable, allowing for the development of a range of solutions from tiny controllers to large automation systems without having to compromise. ISaGRAF gives you the flexibility to use it in combination with the hardware platform and operating system of your choice, thereby permitting the development of automation products that exactly meet your requirements.

ISaGRAF not only addresses the technical aspects in the design of the automation product, but also addresses the usability, meeting the industrial market expectations for standards, performance and functionality. ISaGRAF, with its compliance with IEC 61131 and IEC 61499, allows products to meet international automation standards, facilitating certification towards IEC 61508 and critical application safety levels such as SIL 3.

ISaGRAF addresses the requirements of wide variety of applications and specific market needs while at same time providing for flexible licensing, the ability to brand-label and the integration and encryption of your core competency to protect your intellectual property.



# the foundation of modern automation

## Product elements

ISaGRAF consists of two main components: the Application Workbench and the Runtime Target (“Virtual Machine”).

The Runtime Target is a portable execution engine that runs the developed applications. The portability of the applications generated by the Workbench enables the Runtime Target to execute them without modification, regardless of operating system or processor. Because only one development environment is needed, users leverage the full benefits of a true automation approach.

ISaGRAF Runtime Targets can run on any operating system. Examples include Windows NT, XP, Windows CE, NT Embedded, RTX, Linux, RTAI Linux, Time Sys, QNX, VxWorks and many more. ISaGRAF can also run on any hardware platform or processor including Intel, Motorola, ARM, SHx, PowerPC, NetSilicone etc.

The Application Workbench is a complete programming environment used to develop highly portable applications. It fully supports IEC 61131 and IEC 61499 programming languages. The Workbench also provides tools for editing, debugging, code generation, documentation, library management, archiving, on-line monitoring, off-line simulation and on-line changes.

## What you can do with it

ISaGRAF is the only technology on the market to comply with the principles of the IEC 61131 software architecture for distributed control systems. The innovative implementation of these principles makes it a viable choice to build automation products such as embedded controllers, PLCs, DCS, RTUs, CNC, Motion Controllers etc.

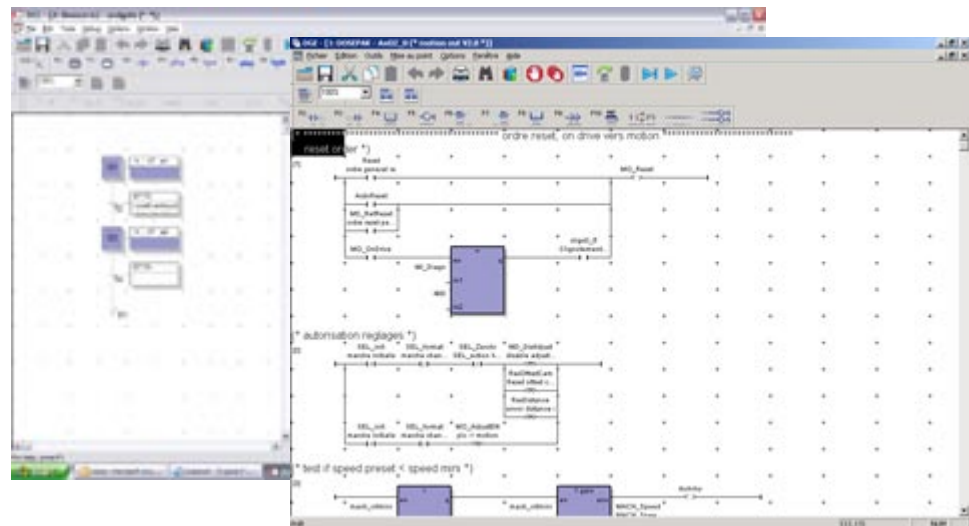

# leaders in industrial software innovation

## IEC 61499 - the emerging standard that will revolutionize the way you build your control products

Developed by the International Electrotechnical Commission (IEC), IEC 61499 presents guidelines for the use of function blocks in distributed industrial process, measurement and control systems. This emerging standard provides a number of remarkable benefits that ease the development and maintenance of robust control systems.

IEC 61499 also has the ability to encapsulate automation functionality such that machine builders can create IEC61499 function blocks for different components of the machine and only need to assemble them to achieve the desired operation. It provides the benefits of object oriented programming in an environment accessible to automation engineers.

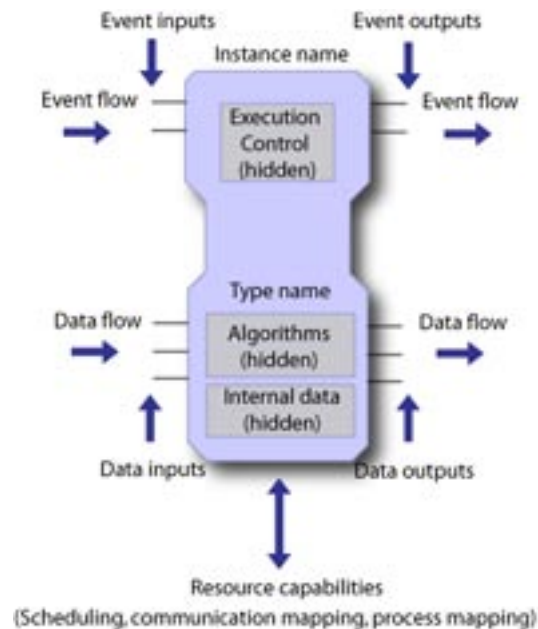

## Implementing an IEC 61499 application

In creating an automation system, one would traditionally start by looking at individual control applications and then determine how these interact with one another. Under ISaGRAF 5.0, although the same methodology may be used in defining the local behavior of the control devices, one would define global diagrams using the IEC 61499 environment and would drop in function blocks to regulate the behavior of the cooperating devices.

In fact, in using the IEC 61499 standard, one can design an application distributed over multiple resources and spread over multiple devices (known as Configs under IEC 61131).

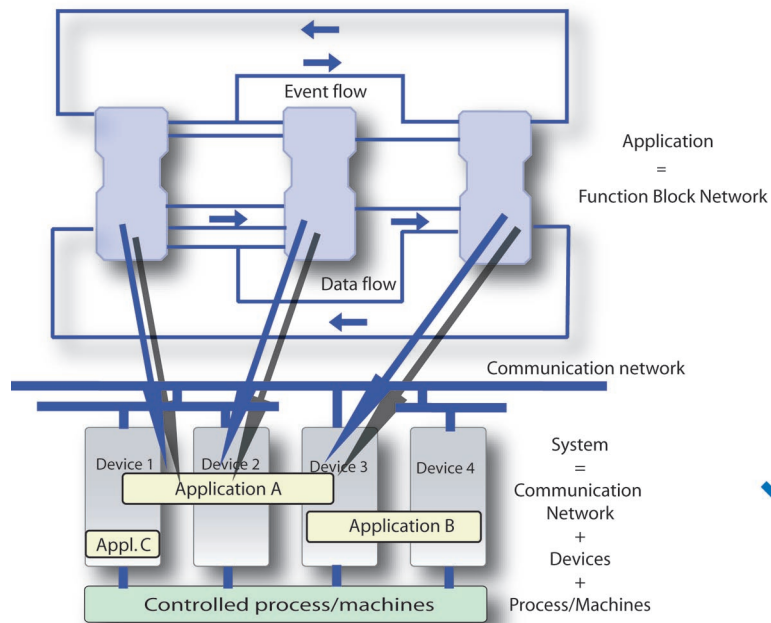

These applications are regulated through IEC 61499 function block diagrams and their collaboration is then clearly and rigorously defined. Furthermore, the interactions between devices are automatically regulated and synchronized by the IEC 61499 function block diagrams rather than through the use of manually implemented algorithms. The devices could be PLCs, micro-controllers or intelligent field instrumentation such as flow meters or valves.

The IEC 61499 function block diagrams provide a high-level management tool over a control system. It gives the ability to overlook the overall behaviour of your control system.

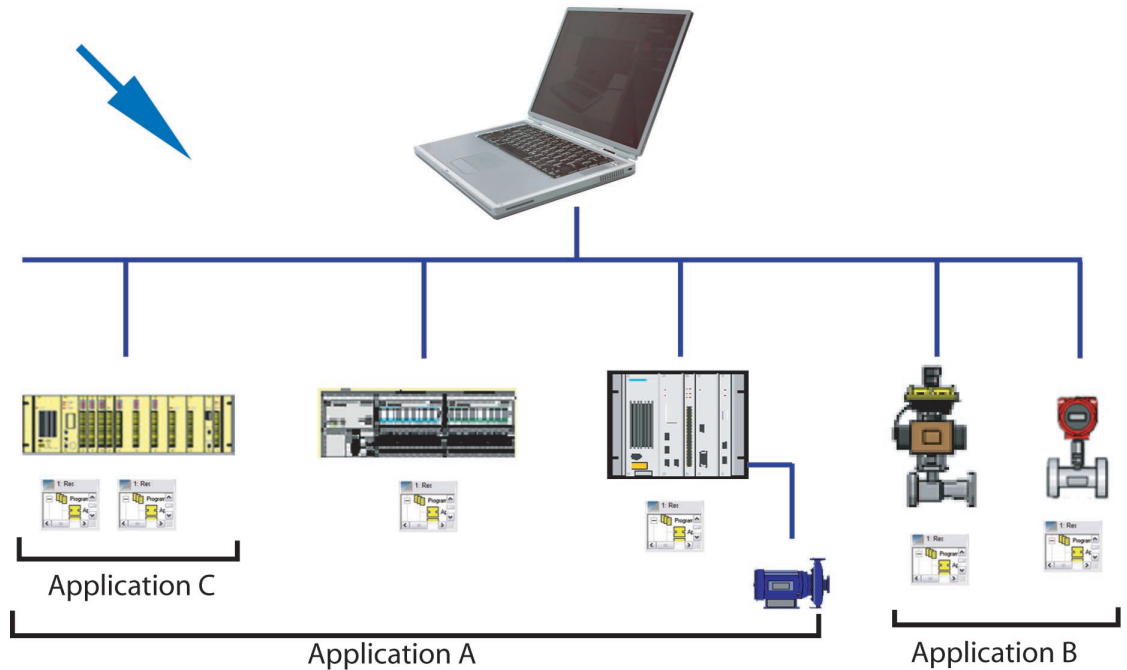

Implementation of a IEC 61499 application

# fast, robust, scalable & affordable

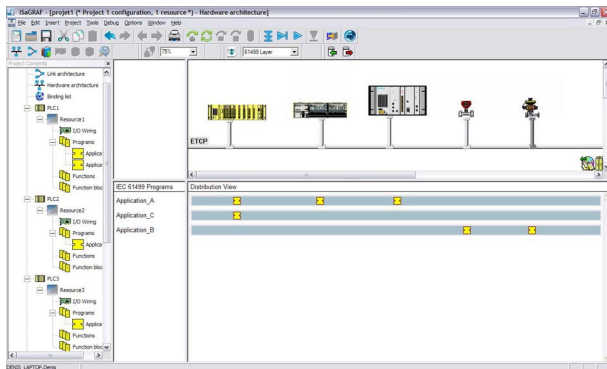

IEC 61499 Hardware View

With ISaGRAF, the engineer can intuitively look at a specific application and its regulating diagram.

The significance of the IEC 61499 standard is that it defines a distributed model for splitting different parts of an industrial and automation process and complex machinery control into functional modules (named function blocks) which can be distributed and interconnected together over multiple controllers. These interconnected function blocks can be supplied by multiple vendors.

These screenshots represent the way in which the ISaGRAF software represents the aforementioned system. There are 2 separate views (Hardware View, Resource View) as well as one of the associated IEC 61499 function block diagrams.

Resource View

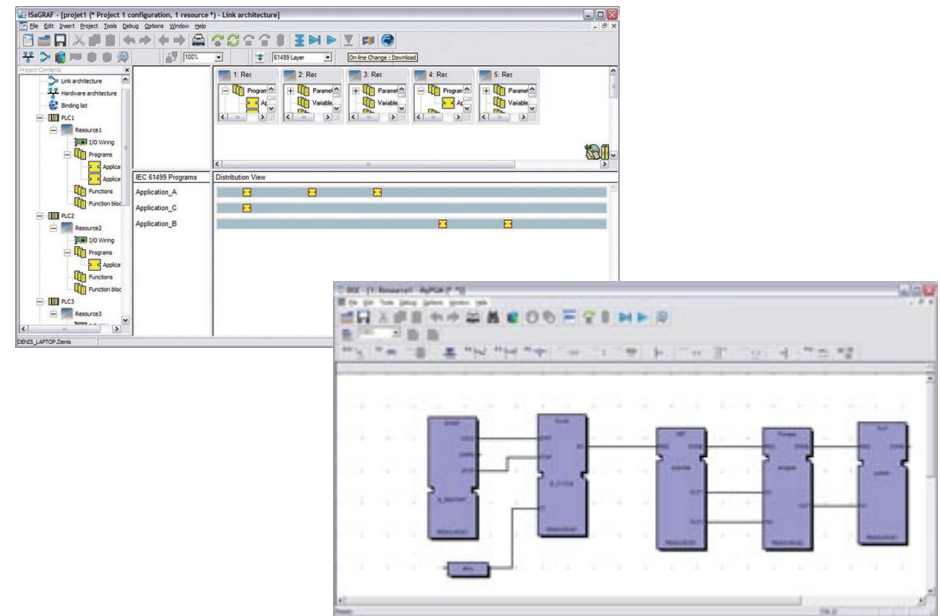

IEC 61499 function block diagram

## Take advantage of the benefits offered by IEC 61499

- Regulates the flow of control decisions for a interacting distributed control system
- Ensures integrity of the distributed application
- Provides for consistency of the data
- Provides means to ensure synchronous operation between devices
- Eliminates the need to have separate synchronization schemes
- Eases considerably the development and maintenance of robust control systems
- Provides mechanism for spreading an application and controls its execution in a multi-resource and multi-device environment.

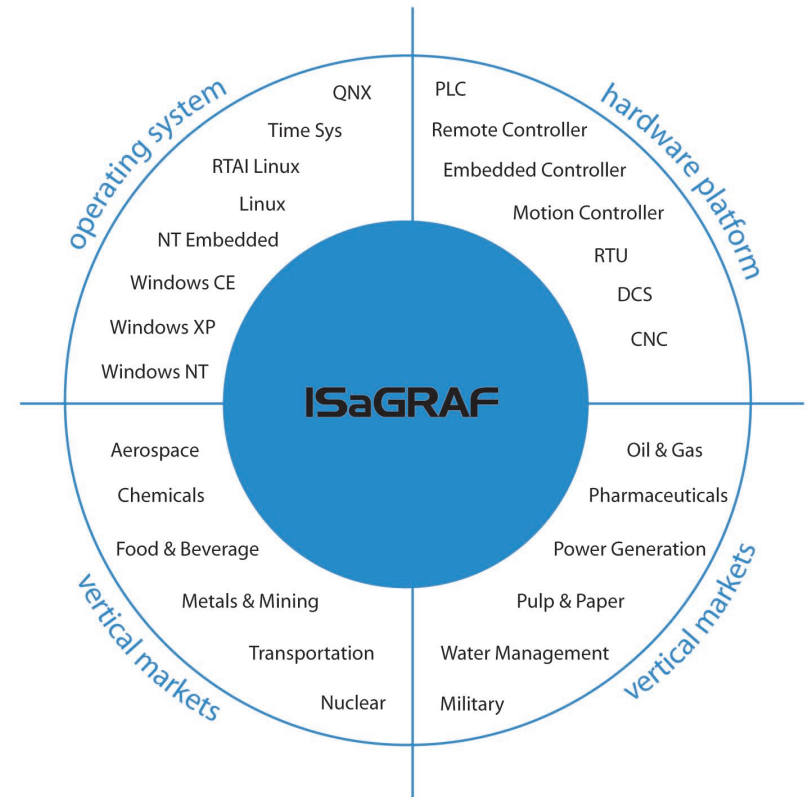

## Integrated Motion Control Toolkit



ISaGRAF offers an integrated Motion Control Toolkit designed to provide an interface between the ISaGRAF IEC 61131-3 environment and the manufacturer's hardware.

The PLCopen standard compliant function blocks are an integral part of ISaGRAF's IEC 61131-3 set of function blocks. The OEM has the opportunity to integrate its proprietary commands in the standard function blocks and the overall logic is then implemented within the IEC 61131-3 environment.

The Motion Control Toolkit is hardware and OS independent; therefore, it can be implemented on any OS as well as any hardware platform.

The ISaGRAF Motion Control Solution is certified compliant to the PLCopen Motion Control Specification.